RG3210 Roll Grooving Tool



PARTS ORDERING INFORMATION

When ordering parts, the following information is necessary for Victaulic to process the order promptly:

1. Tool Model Number – RG3210
2. Tool Serial Number – The Serial Number can be found on the side of the tool.
3. Quantity, Item Number, Part Number, Description
4. Where to send the part(s) – Company Name and Address
5. To whose attention to send the part(s)
6. Purchase Order Number

Parts may be ordered from the nearest Victaulic Sales Office.

MAIN ASSEMBLY

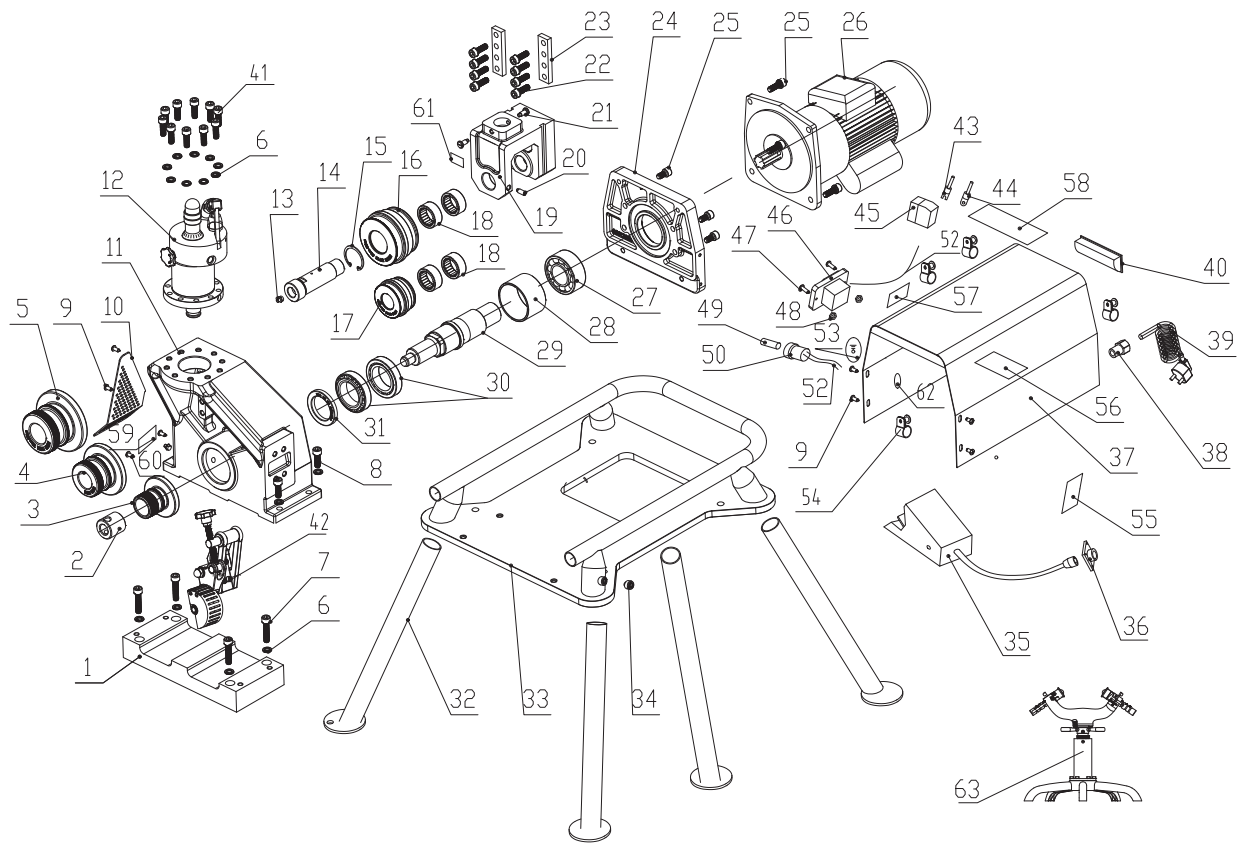

Item #	Drawing #	Qty.	Description
1	TWG/13A-02-008	1	Spacer
2	TWG/13A-02-013	1	Main Shaft Fastening Nut
3	TWG/13A-02-005(2)	1	Knurl Wheel φ60-φ76
4	TWG/13A-02-005-01(2)	1	Knurl Wheel φ89-φ168
5	TWG/13A-02-005-02(2)	1	Knurl Wheel φ219-φ325
6	GB93-87	24	Spring Washer φ10
7	GB70.1-2000	4	Hex Socket Head Cap Screw M10x45
8	GB70.1-2000	8	Hex Socket Head Cap Screw M10x35
9	GB67-2000	6	Cross Recessed Pan Head Screw M6x8
10	TWG/13A-02-010A	1	Safety Cover of Unit Head
11	TWG/13A-02-001A	1	Unit Head
12	TWG/2A-02-000	1	Oil Pump Assembly
13	M10x1	2	Oil Cup
14	TWG/13A-02-004	1	Pinch Roller Shaft
15	GB/T893.1-86	2	Circlip φ47
16	TWG/13A-02-003(2)	1	Pinch Roller φ60-φ168
17	TWG/13A-02-003-01(2)	1	Pinch Roller φ219-φ325
18	4084105D	4	Bearing 4084105D
19	TWG/13A-02-002	1	Pinch Roller Holder
20	GB79-2000	1	Hex Set Screws w/ Full Dog Point M10X30
21	TWG/2-04-010	2	Piston Fixed Ring Screw
22	GB70.1-2000	8	Hex Socket Head Cap Screw M10x20
23	TWG/2A-01-002	2	Guide Rail
24	TWG/13A-02-006	1	Rear Cover
25	GB70.1-2000	8	Hex Socket Head Cap Screw M10x25
26	TWG/13A-02-012A	1	Motor 1500W
27	GB296-1994	1	Bearing 5208
28	TWG/13-02-009	1	Bushing
29	TWG/13A-02-009	1	Main Shaft
30	GB/T297-1994	2	Bearing 32010
31	GB/T13871-1992	1	Seal Ring 50x72
32	TWG/13A-03-002	4	Support Foot 790mm

Item #	Drawing #	Qty.	Description
33	TWG/13A-03-001B	1	Base Welding Assembly
34	GB79-2000	4	Hex Socket Head Cap Screw M10x25
35	LTH1/6	1	Foot Switch
36	TP20-3F	1	Aviation Plug
37	TWG/13A-02-007A	1	Safety Cover
38	PG9	1	Cable Joint PG9
39	3X1.5	1	European Plug Wire 3X1.5
40	YLJX-01	1	Plastic Handle
41	GB70.1-2000	10	Hex Socket Head Cap Screw M10x30
42	TWG/13A-05-00	1	Guide Wheel Assembly
43	SV1.5-4	15	Y Wire Connector SV1.5-4
44	OT1.5-4	2	O Wire Connector OT1.5-4
45	LC1E1210M5N-GB14048.4	1	AC Contactor LC1E1210M5N
46	LC3-10-B	1	Switch
47	GB67-2000	2	Cross Recessed Pan Head Screw M4x16
48	GB41-2000	6	Nut M4
49	1A	1	Fuse
50	10A 250V AC	1	Fuse Holder
51	10A 250V AC	1	Cable Line 3x1mm2
52	3x1mm2-GB/T5023.5	1	Wire 1x0.5mm2
53	1x0.5mm2-GB/T5023.3	1	Groundwire Mark
54	TWG/2-BT-01	4	R Wire Clamp 6.4
55	11470	1	Electrical Danger Plate
56	11468	1	Serial Number Plate
57	11469	1	Electrical Danger plate
58	11471	1	C Diameter Plate
59	TWG/13-06-002	1	Tool Head Number Plate
60	φ2*4	2	Copper Rivet
61	11240	1	Pinch Point Plate
62	φ4	1	Star Ring
63	TWG/13A-04-000	1	Pipe Stand

PUMP ASSEMBLY

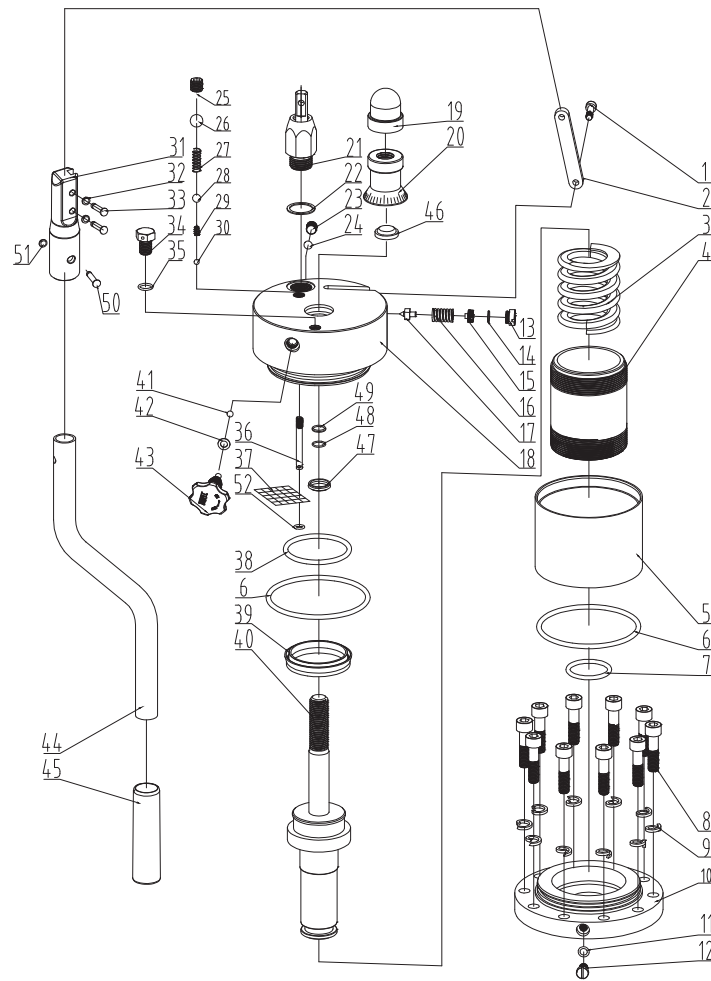

Item #	Drawing #	Qty.	Description
1	TWG/2A-02-032	1	Hex Socket Head Cap Screw
2	TWG/2A-02-009A	1	Connection Plate
3	TWG/2A-02-014	1	Spring
4	TWG/2A-02-015	1	Piston Cylinder Sleeve
5	TWG/2-02-016	1	Oil Box
6	85x3.1-GB3452.1-1992	2	O-Type Seal Ring
7	35x3.1-GB3452.1-1992	1	O-Type Seal Ring
8	M10x30-GB/T70.1-2000	10	Hex Socket Head Cap Screw
9	10-GB/T 93-87	10	Spring Washer
10	TWG/2A-02-017	1	Pump Seat
11	12x2.4-GB3452.1-1992	1	O-Type Seal Ring
12	TWG/2A-02-021	1	Discharge Oil Plug
13	TWG/2A-02-024	1	Safety Valve Bulkhead
14	15x1.9-GB3452.1-1992	1	O-Type Seal Ring
15	TWG/2A-02-023	1	Safety Valve Screw
16	TWG/2A-02-025	1	Overflow Flat Spring
17	TWG/2A-02-026	1	Concial Valve
18	TWG/2A-02-012B	1	Pump Body
19	TWG/2A-02-029	1	Depth Adjuster Lock
20	TWG/2A-02-030	1	Depth Adjuster
21	TWG/2A-02-040-00	1	Hex Pump Assembly
22	TWG/2-02-011	1	Copper Washer D28 x D22 x 1.5
23	TWQ/5-03-009	1	Plug G1/8"-28
24	Φ6-GB882-86	2	Steel Ball
25	TWG/2-02-002	1	Screw M12 x 1
26	Φ9.525-GB882-86	1	Steel Ball

Item #	Drawing #	Qty.	Description
27	TWG/2A-02-003	1	Spring
28	Φ8-GB882-86	1	Steel Ball
29	TWG/2-02-001B	1	Compress Spring
30	Φ5-GB882-86	1	Steel Ball
31	TWG/2B-02-016	1	Handle Seat
32	Φ5-GB/T-896	2	Retaining Ring for Shaft
33	TWG/2A-02-034	2	Pin Shaft Φ 6 x 25.5
34	TWG/2B-02-015	1	Added Oil Plug
35	15x1.9-GB3452.1-1992	1	O-Type Seal Ring
36	TWG/2-02-022	1	Suction Pipe
37	100#	1	Strainer
38	60x3.5-GB3452.1-1992	1	O-Type Seal Ring
39	D50xd40x10-Q/ZB249-77	1	Y-Type Seal Ring
40	TWG/2A-02-013	1	Limit Piston
41	Φ6-GB308-84	2	Steel Ball
42	D12xd8x1-TWG/2-02-018	1	Copper Washer
43	TWG/2B--02-040-00	1	Relief Valve
44	TWG/2-02-000-2	1	Handle
45	Φ22X120	1	Handle Sleeve
46	D32xd20x5-GB/T10708.3-1989	1	Dustproof Ring
47	D28xd20x5	1	Y-Type Seal Ring
48	24x2.4-GB1235-76	1	O-Type Seal Ring
49	TWG/2A-02-031	1	Washer D24 x d20 x 1.5
50	TWG/2B-02-013	1	Pin Shaft Φ 8 x 36
51	TWG/5-02-020	1	Circlip for Shaft
52	TWG/2B-02-019	1	O-Type Seal Ring

PIPE STAND

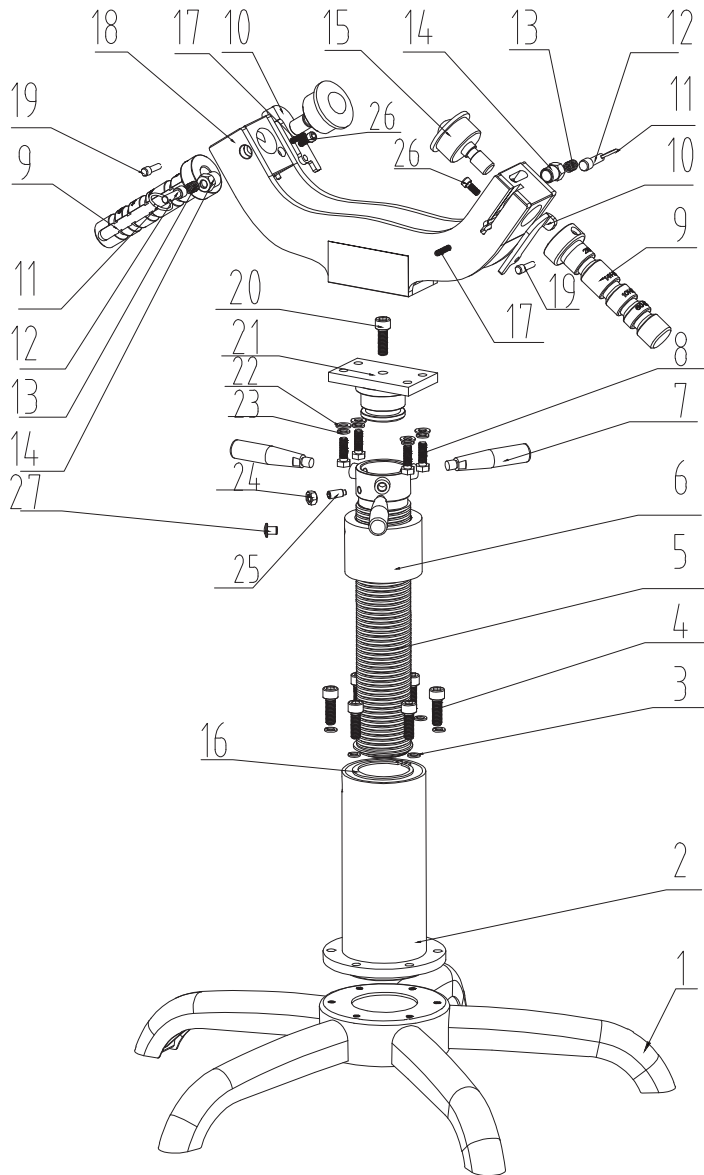

Item#	Drawing #	Qty.	Description
1	TWG/2A-05A-014	1	Support Base
2	TWG/13A-04-002	1	Support Tubes
3	M8;GB93-87	6	Spring Washer
4	GB/T70.1-2000	6	Hex Socket Head Cap Screw M8x16
5	TWG/13A-04-001	1	Feed Screw
6	TWG/13A-01-003	1	Feed Nut
7	TWG/13A-04-004	3	Support Handle
8	M8x25-GB5780-86	4	Hex Headed Bolt
9	TWG/13A-01-001	2	Fixed Shaft
10	TWG/13A-01-010	2	Position Block
11	Φ40	2	Ring
12	TWG/13A-01-002	2	Fasten Pin
13	TWQ/6-02-014.1	2	Position Spring
14	TWG/13A-01-003	2	Fasten Screw

Item#	Drawing #	Qty.	Description
15	TWG/13A-01-004	2	CV Joint Ball
16	φ58-GB894.1-86	2	Retaining Ring
17	TWG/13-01-009	2	Position Spring
18	TWG/13A-01-005	2	Support Body
19	M6x10-GB/T70.1-2000	1	Hex Socket Head Cap Screw
20	M10x25-GB/T70.1-2000	1	Hex Socket Head Cap Screw
21	TWG/13A-01-006	1	Connection Seat
22	Φ8;GB/T97.1-2002	4	Flat Washer
23	Φ8;GB93-87	4	Spring Washer
24	M8;GB6170	1	Nut
25	M8X20-GB79-2000	1	Hex Set Screws w/ Full Dog Point
26	M6x30-GB/T70.1-2000	1	Hex Socket Head Cap Screw
27	M8X10-GB819-85	1	Hex Countersunk Head Screw

STABILIZER

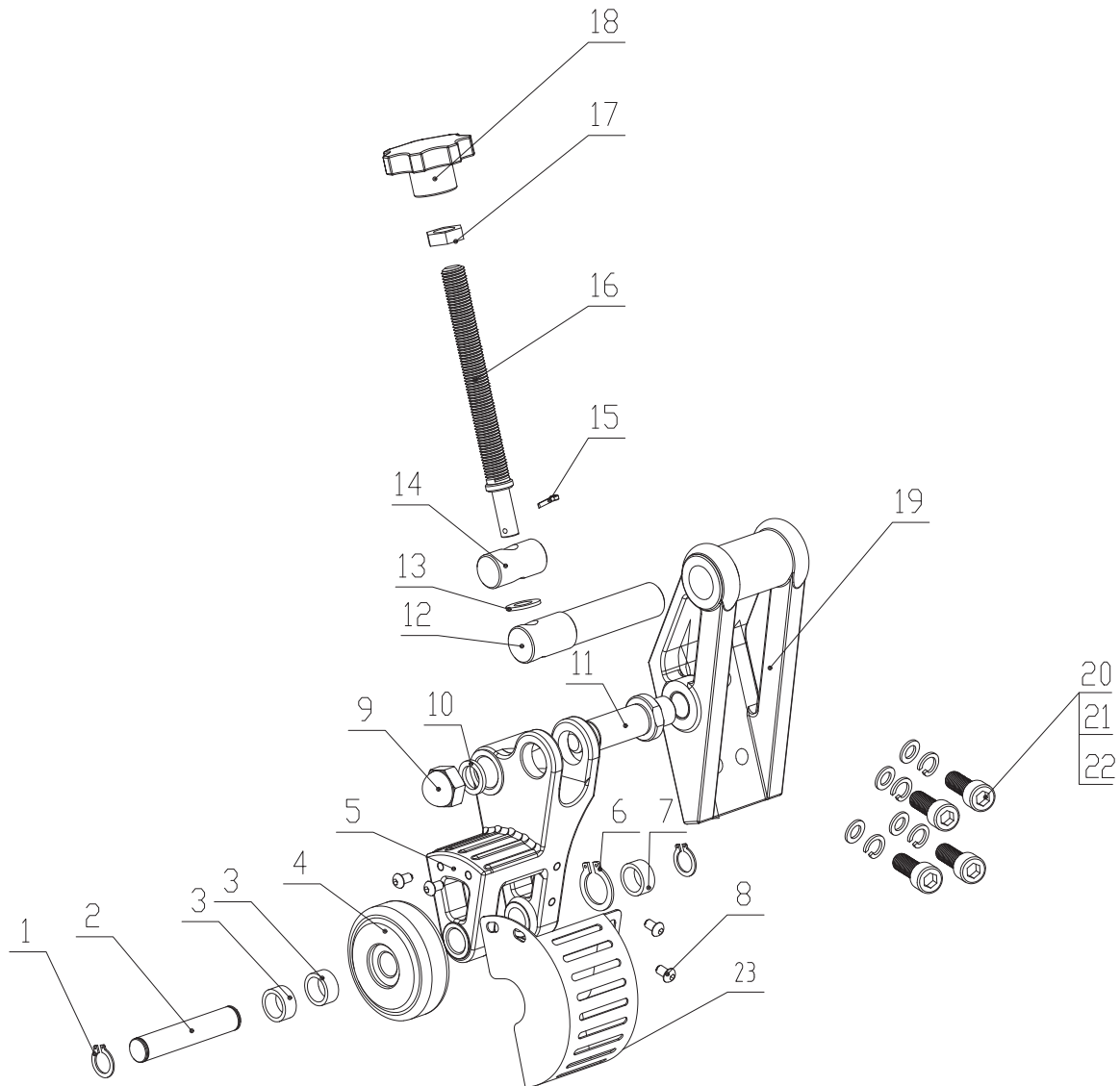

Item#	Drawing #	Qty.	Description
1	GB894.1-1986	2	Circlipsφ17
2	TWG7A-03-003	1	Guide Wheel Shaft
3	6003RS	2	Bearing 6003RS
4	TWG5A-06-10-01	1	Guide Wheel
5	TWG/13A-05-002	1	Wheel Frame (Right)
6	GB/T893.1-1986	1	Circlips φ35
7	TWG7-03-008B	1	Wheel Bush
8	M16-GB/T923-1988	4	Acorn Hex Nut
9	GB/T923-1988	1	Cap Nut M16
10	GB/T93-1987	1	Spring Washer Φ16
11	TWG7A-03-009	1	Shaft of Wheel Frame

Item#	Drawing #	Qty.	Description
12	TWG7A-03-005B	1	Supporting Axle
13	GB/T97.1-2002	1	Flat Washer Φ12
14	TWG7-03-004	1	Axis of Rotation
15	GB/T91-2000	1	Pin φ3x20
16	TWG7-03-006C	1	Screw Rod
17	TWG7A-03-010A	1	Hand Wheel M16 x 63
18	TWG7-03-010A	1	Hand Wheel M16x63
19	TWG7-03-001C	1	Guide Wheel Base (Right)
20	GB/T84-1987	4	Flat Washer Φ10
21	GB/T93-1987	4	Spring Washer Φ10
22	GB70.1-2000	4	Hex Socket Head Cap Screw M10x35

This page intentionally blank.

This page intentionally blank.

RG3210 Roll Grooving Tool

For complete contact information, visit victaulic.com

RP-RG3210 12680 REV B UPDATED 02/2020 RPL0321000

VICTAULIC IS A REGISTERED TRADEMARK OF VICTAULIC COMPANY AND/OR ITS AFFILIATED ENTITIES IN THE UNITED STATES AND/OR OTHER COUNTRIES. © 2020 VICTAULIC COMPANY. ALL RIGHTS RESERVED.

