

Profit gate valves type FGOSY are resilient seated gate valves. The flanged cast iron body has a ductile iron wedge with vulcanised rubber lining. The valves are designed to be used in fire protection sprinkler systems.

Characteristics

- Indoor & outdoor use.
- Manually operated with a hand-wheel.
- Installation between flange-types EN 1092-PN10/16:
 - DN50 to DN150: PN 10/16.
 - DN200 to DN300: PN16.
- F/F dimension comply with EN 558/series3, ASME B16.10 and ISO 5752 .
- Full bore waterway body.
- Resilient wedge.
- Suitable for use in vertical and horizontal piping.
- Anti-corrosion protection : high grade polyester powder coating, RAL 3000, meets or exceed AWWA C550 standards.
- Pre-notched stem to accommodate an (optional) supervisory switch.

Working pressure

20,7 barg / 300 PSI

Working temperature

+1 to 80°C

Material specifications

Component	Specification	European standard	ASTM standard
Body	Ductile cast iron	EN-GJS-450-10	A 536 gr 65-45-12
Wedge	Ductile cast iron + EPDM	EN-GJS-450-10	A 536 gr 65-45-12
Wedge nut	Stainless steel	CF8	A 351 CF8
Bonnet	Ductile cast iron	EN-GJS-450-10	A 536 gr 65-45-12
Stem	Stainless steel	X5 Gr Ni 18-10	A 276 Grade 304
Yoke	Ductile cast iron	EN-GJS-450-10	A 536 gr 65-45-12
Stem nut	Bronze	/	B 148 C 95200
Packing	Graphite (Asbestos-free)	/	/
Gland	Ductile cast iron	EN-GJS-450-10	A 536 gr 65-45-12
Gland stud	Stainless steel	X5 Gr Ni 18-10	A 276 Grade 304
Fasteners	Carbon steel	Gr 4.6	A 307 Gr B
Body / bonnet gasket	EPDM rubber	/	D2000
Plug (npt)	Malleable iron	/	A 47 Grade 22010
Hand-wheel	Ductile cast iron	EN-GJS-450-10	A 536 Gr 65-45-12



Dimensions

Dimensions (mm/inch)								
Size	2"	2,5"	3"	4"	6"	8"	10"	12"
L	178/7,0	190/7,5	203/8,0	229/9,0	267/10,5	292/11,5	330/13,0	356/14,0
H (close)	332/131,1	365/14,4	416/16,4	455/17,9	614/24,2	764/30,1	894/35,2	1039/40,5
H (open)	380/15,0	430/16,9	500/19,7	550/21,7	764/30,1	974/38,3	1155/45,5	1344/52,9
D	184/7,25	184/7,25	254/10,0	254/10,0	305/12,0	356/14,0	445/17,5	445/17,5
Weight (kg)	-	21,00	28,50	30,00	52,00	79,00	116,50	162,00

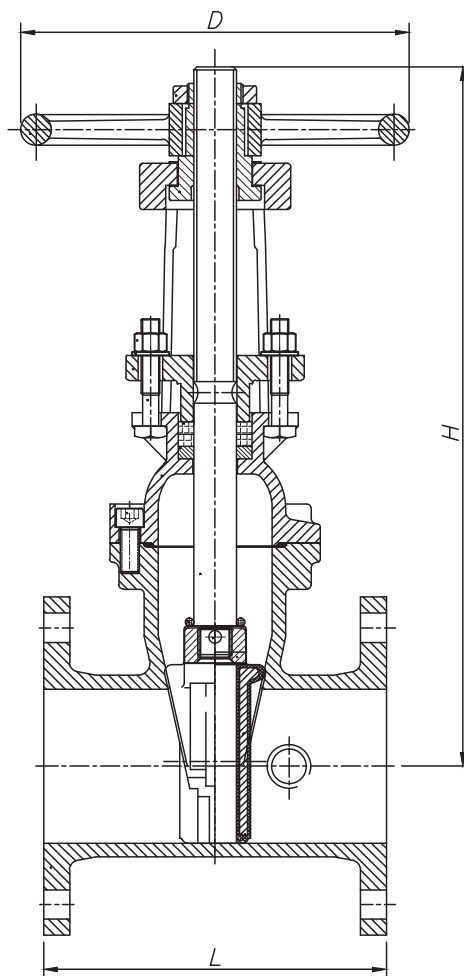

Marking

Body:

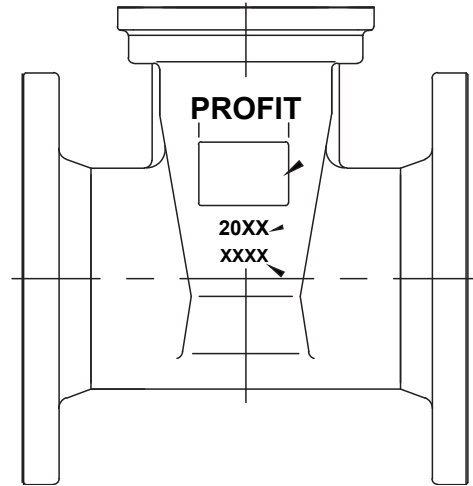
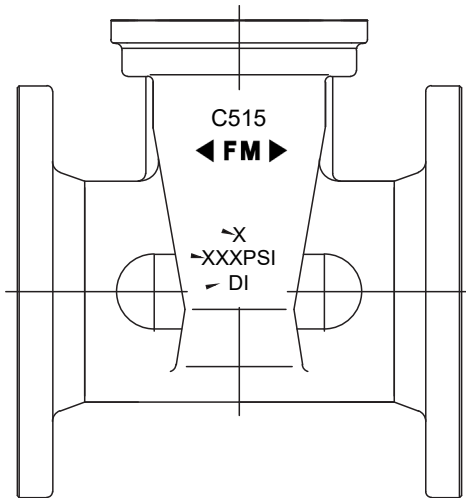

Marking plate:

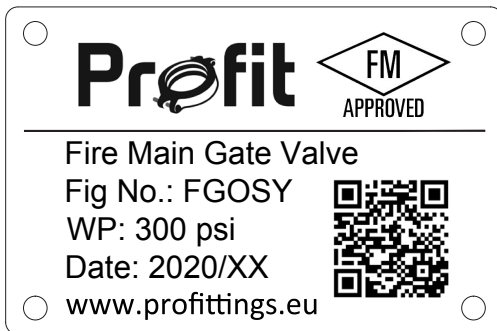

Performances

Cv/Kv-values:

Definition/formulas:

Kv-Value: Actual flow of water (m³/hr) creating pressure loss of 1 bar.

Pressure loss coefficient **Zeta (K) value:** Ratio of static and dynamic pressure loss.

Pressure loss coefficient, Zeta (K-value) = Diff pressure / (500 X V²)
 Diff pressure (Pa)
 V: Water flow velocity (m/sec)
 Actual diff pressure (bar) = (Q/Kv)²

Zeta values:

- DN 40-125: 0,06
- DN 150-250: 0,04
- DN 300-800: 0,02

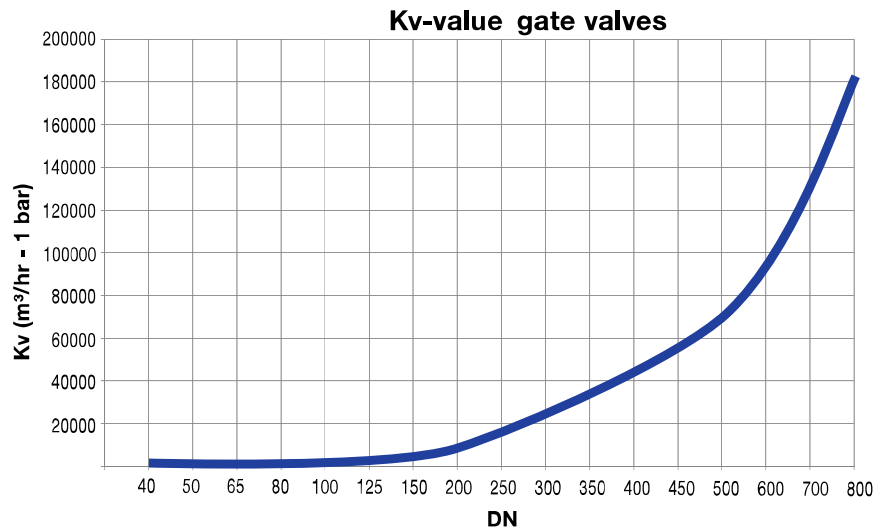

Flow velocity (m/sec)	Q m ³ /h			
	DN 100	DN 125	DN 150	DN 200
1.0	28.3	44.2	63.6	113.1
1.5	42.4	66.3	95.4	169.6
2.0	56.5	88.4	127.2	226.2
2.5	70.7	110.4	159.0	282.7
3.0	84.8	132.5	190.9	339.3
3.5	99.0	154.6	222.7	395.8
4.0	113.1	176.7	254.5	452.4
4.5	127.2	198.8	286.3	508.9
5.0	141.4	220.9	318.1	565.5

Opening %	CV/KV							
	DN 100		DN 125		DN 150		DN 200	
	CV	kv	CV	kv	CV	kv	CV	kv
10%	75	64	143	122	158	135	343	293
20%	186	159	278	238	319	273	642	549
30%	289	247	428	366	539	461	994.5	850
40%	420	359	620	530	805	688	1455.5	1244
50%	642	549	867	741	1198	1024	2023	1729
75%	1280	1094	1787	1527	2732	2335	4719	4033
100%	2128	1819	3028	2588	6247	5339	8478	7246

Certifications

Size		FM
DN 100	4"	Up to 20,7 bar / 300 PSI
DN 125	5"	Up to 20,7 bar / 300 PSI
DN 150	6"	Up to 20,7 bar / 300 PSI
DN 200	8"	Up to 20,7 bar / 300 PSI
DN 250	10"	Up to 20,7 bar / 300 PSI
DN 300	12"	Up to 20,7 bar / 300 PSI



Storage and handling

- Upon receipt, carefully check complete the valve on any damage during shipment.
- Valves should unloaded carefully , they should not be lifted by handwheel or stem or by using the waterway-passage through the valve. Do not drop onto the ground.
- FGOSY valves must be stored indoor, protected the rubber seating from direct sunlight. Storage is recommended with the disc slightly turned open.
- When stored outside, protect the valve from weather conditions and avoid accumulation of water, dirt, or debris.



Installation

- Inspection before installation. Checklist:
 1. Check pressure rating of the valve is compatible with the service conditions. FGOSY valves may be installed with any schedule or pressure class of pipe that is listed or approved.
 2. Check that the available length between the piping flanges matches the total length of the valve (+ 2 x gasket thickness).
 3. The FGOSY valve-flanges are drilled to EN 1092-1/PN10/16 except DN 200 is drilled to EN 1092-1/PN16.
 Check that the dimensions (or standard) of the mating flanges match up with the flange-drilling of the valve.
 4. Verify that there are two gaskets available to install in between the flanges on both sides. Check the pressure/temperature rating of the gaskets.
 Check availability of correct bolts & nuts to complete both flange-connections.
 5. Open and close the valve to ensure that it operates properly.
 6. Check that valve-body, and adjacent pipes are clean inside.
 7. Check that the 4 flange-facings are clean and free from damage of the sealing surface.

8. Pipework must be supported near the valve and pipes must be well aligned so that no extra stress will be exerted on the valve-body during installation.
 9. To prolong the valve-life, we recommend to install the valve not closer than 5-6 x DN when installed downstream near a fitting (bends and tees).
 10. The gate valves are not intended to be used for regulating or throttling services.
 11. The valves may be installed in:
 - a) Horizontal pipework (attention: stem should not be placed horizontal because shut-off performance may be impaired)
 - b) Vertical pipework with stem horizontal
 12. For replacements: all pipes need to be depressurized and purged before starting the installation.
 13. Personnel for the installation must be qualified for the task.
- Installation of the valve:
 1. The valves are bi-directional.
 2. Close the valve.
 3. Insert the valve between the flanges with the appropriate gaskets.
 4. Tighten the bolts . For correct tightening please apply cross-over sequence. For bolt-torque please refer to the gasket datasheet.
 - Operation of the valve:
 1. Check the operation by fully opening (turn clockwise) and closing (turn anti-clockwise) the valve.
 2. Turn the valve fully open before filling and pressurizing the system.



Maintenance

- FGOSY valves are basically installed maintenance-free. However we advise to verify at least annually (or scheduled in agreement with the local authority or competent maintenance company) that the valve operates properly. Also check for any leaks between flanges or in the stem area. Stem-leakage can be solved easily by tightening the 2 gland nuts clockwise, till leakage has stopped. In the event that gland packing needs replacement please contact Profit Europe technical dpt.
- When the valve is blocked, please do not use excessive force or torque on the handwheel. Important temperature differences can be the cause of the problem. Take the valve out to check the cause.
- When a major problem of any kind occurs, please contact technical dpt. of Profit Europe.
- The owner of the system is responsible for testing and inspection of the sprinkler system , in accordance with the applicable standard. We recommend that this testing is done by a qualified inspection service company.